

Electrical Specifications

Absorber lining: Fully covering

Absorber type: Pyramidal electromagnetic

Back wall absorber: 30 cm (12")

- Reflectivity:
800-1000 MHz: -34 dB or less

Rest of the absorbers: 10 cm (4")

- Reflectivity:
800-1000 MHz: -16 dB or less

Leakage:

- Maximum: 41 dBuV/m
- Typical: 35 dBuV/m (at 3 m distance, 800-1000 MHz, using 27 dBm TX power and standard patch antenna)

Mechanical Dimensions

Size: 1200 x 800 x 800 mm
(47" x 31" x 31")

Material: Stainless steel

Door: Shielded, opening 45 x 45 cm
(17.7" x 17.7")

Standard measurement distance:
45 cm (17.7")

RF connectors:
2 x N-type feed-through

Delivery:
Crate size: 155 x 106 x 97cm (w x d x h, typ.)
Gross weight: 190 kg (typ.)

FRONT VIEW

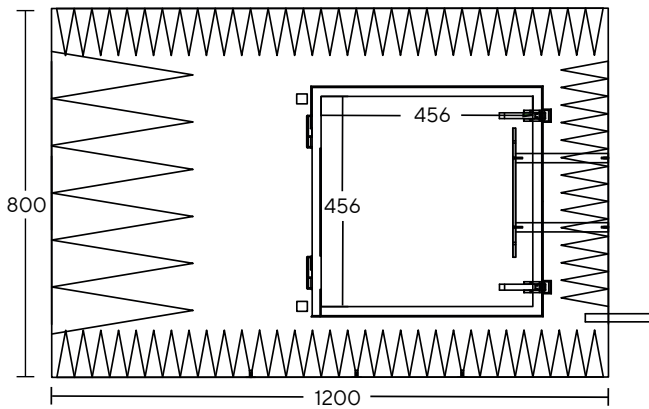

SIDE VIEW

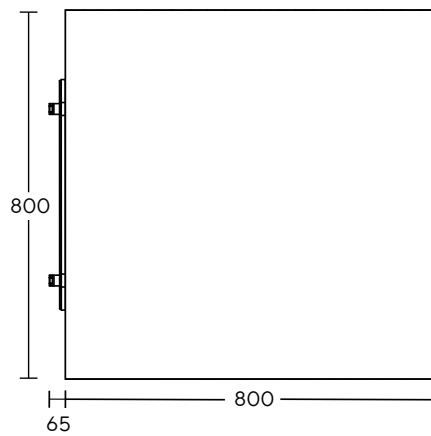

TOP VIEW

